

**Digital Undercounter  
 ecostore HP Concept Refrigerated  
 Counter - 2 Door with Splashback  
 (60Hz)**

ITEM # \_\_\_\_\_

MODEL # \_\_\_\_\_

NAME # \_\_\_\_\_

SIS # \_\_\_\_\_

AIA # \_\_\_\_\_

**710249 (EK2R3AAH)**

 2-door Refrigerated  
 Counter, -2+10°C. AISI 304  
 (R134a) with splashback, UK  
 plug - 60 Hz

### Short Form Specification

**Item No.** \_\_\_\_\_

AISI 304 stainless steel panels, AISI 430 bottom panel, galvanized back panel. Worktop thickness 50mm, fitted with integrated rear splashback h=100mm. N. 2 full doors. Built-in refrigeration unit. Operating temperature: -2+10°C. R134a gas in refrigeration circuit. Supplied with 1 grid for each door compartment

### Main Features

- Adjustable temperature range from -2 °C to +10 °C to suit meat, fish and dairy storage requirements.
- Refrigerated compartment designed to accept GN 1/1 containers.
- Combination of doors and drawers to suit varying needs, with the possibility to change the configuration on site.
- Digital control panel.
- Forced air circulation for rapid cooling and an even temperature distribution.
- Anti-tilt runners accept GN 1/1 containers.
- Self closing stainless steel doors (< 90°).
- Fully compliant HACCP digital control: when temperature exceeds critical limits, acoustic and visual alarms are activated. Up to two months of event are kept in memory.
- Prearranged to fit RS485 port to facilitate connection to a remote computer and integrated HACCP systems.
- 0mm clearance installation space: tower configuration cooling unit guarantee performance with frontal ventilation only; this unique solution allows installation against the wall or side by side with other appliances, even on the cooling unit side to maximize the use of kitchen space.
- Hot gas automatic evaporation of defrost water.
- Preservation performances and temperature uniformity within the cell guaranteed at 5-HEAVY DUTY (40°C) working conditions according to EN16825:2016 test protocol.
- Combination of doors and drawers to suit any configuration needed, with the possibility to change the configuration on site. Right cooling unit available on request.
- Frontal and easy access to all components in the cooling unit.
- Mounted on stainless steel feet to give 150 mm (-5/+50 mm) clearance for ease of cleaning the floor.
- Certified safety CE requirements.
- External bottom panel in stainless steel.
- Equipped with forced air circulation system for rapid cooling and temperature distribution within the cell.
- External back panel in galvanized steel.
- Raised rear upstand permits unit to be connected up against the wall for better hygiene.
- Connectivity ready for real time access to connected appliances from remote and data monitoring (requires optional accessory).
- Digital white-digit display with internal temperature display and setting, manual activation of defrost cycle and turbo frost cycle (to rapidly cool warm loads).
- Easy serviceability thanks to the intuitive control panel with access via app.
- Integrated RS485 port to facilitate connection to a remote computer and integrated HACCP systems.
- Tropicalized unit.

### Construction

**APPROVAL:** \_\_\_\_\_

- Built-in compressor to suit operating conditions.
  - Constructed from AISI 304 Stainless steel throughout to meet the highest hygiene standards.
  - Rounded internal corners for ease of cleaning.
  - Mounted on Stainless steel adjustable legs to give 150 mm clearance for ease of cleaning.
  - Access to all components from the front.
  - Developed and produced in ISO 9001 and ISO 14001 certified factory.
  - Pre-arranged for drain-pipe.
  - Fault code display.
  - Interior base with rounded corners, pressed from a single sheet.
  - Internal and external doors, front and side panels and removable worktop in AISI 304 Stainless steel.
  - Worktop in AISI 304 Stainless steel with a 50 mm profile.
  - Built-in refrigeration unit.
  - Anti-drip profile on stainless steel worktop edge.
  - 2 compartments with 2 doors.
  - If needed, working top can be removed for easier handling during installation (in case of narrow doors).
  - Ease of cleaning and high hygiene standards thanks to the rounded internal corners, the easily removable runners, grids and air conveyors.
  - Internal structure with 15 charging positions (3 cm pitch) available to host GN 1/1 grids, ensuring higher net capacity and a greater storage space.
  - Excellent space optimisation thanks to the compact dimensions.
  - Extractable cooling unit to facilitate maintenance.
- 1/1 GN plastic container, H=150 mm PNC 881112
  - Kit 4 wheels, H=100 mm (2 with brakes) for refrigerated counters PNC 881191
  - Kit 4 wheels, H=150 mm (2 with brakes) for 2&3 compartment refrigerated counters PNC 881193
  - Lock for refrigerator/freezer counters with 2 compartments - h700mm (can be used in kit for Marine conversion) PNC 881242

### Sustainability



- CFC and HCFC free (ecological refrigerant type: R134a, - gas in foam: cyclopentane).
- Top energy efficiency (class A) and granted uniformity even at extreme working conditions (class 5; 40°C and 40% humidity): unbeatable performance, certified by energy test protocol EN16825:2016.
- Removable triple-chamber balloon magnetic gasket to improve insulation and reduce energy consumption and ease of cleaning.
- Fitted with 90 mm thickness of cyclopentane insulation for best insulating performance (thermal conductivity: 0,020 W/m\*K) and lowest environmental impact (GWP=3).

### Included Accessories

- 2 of Kit 1/1 grey rilsan grid and 2 side runners for refrigerated counters PNC 881109

### Optional Accessories

- 2x½ drawer kit for refrigerated counters PNC 881058
- 3x1/3 drawer kit for refrigerated counters PNC 881059
- 1/3 and 2/3 bottle drawer kit for refrigerated counters PNC 881071
- 1/1GN grey rilsan grid for refrigerated counters PNC 881107
- 2 side runners for 1/1 GN ecostore refrigerated counters PNC 881108
- Kit 1/1 grey rilsan grid and 2 side runners for refrigerated counters PNC 881109
- 1/1 GN plastic container, H=65 mm PNC 881110
- 1/1 GN plastic container, H=100 mm PNC 881111

Front

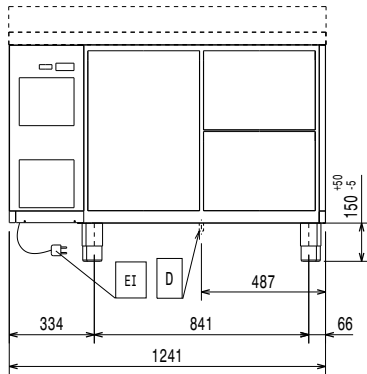

Side

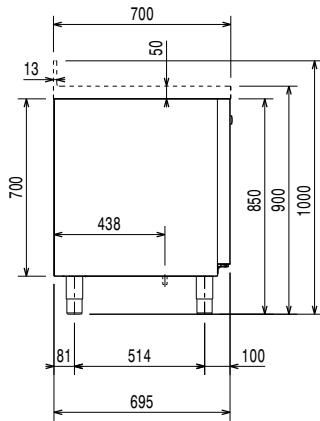

EI = Electrical inlet (power)

Top

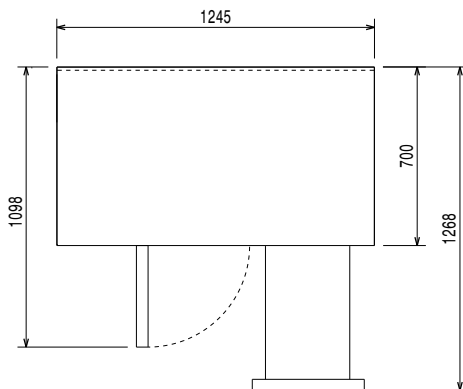

### Electric

**Supply voltage:**

710249 (EK2R3AAH)

220-230 V/1 ph/60 Hz

### Key Information:

**Gross capacity:**

290 lt

**Net Volume:**

181 lt

**Door hinges:**

1 Left+1 Right

**Built-in Compressor and Refrigeration Unit**
**External dimensions, Width:**

1245 mm

**External dimensions, Depth:**

700 mm

**External dimensions, Height:**

1000 mm

**Depth with doors open:**

1110 mm

### Refrigeration Data

**Compressor power:**

1/4 hp

### ISO Certificates

**ISO Standards:**

ISO 9001; ISO 14001; ISO 45001; ISO 50001

### Sustainability

**Refrigerant type:**

R134a

**Refrigeration power:**

0 W

**Refrigerant weight:**

100 g